

Enclosed continuous current (DC) motors

MFA - MF

General information



Enclosed continuous current (dc) motors

- **MFA** (permanent magnets):
 - frame sizes from 56 to 80 mm,
 - power 0.075 to 1.3 kW.
- **MF** (wound inductors):
 - frame size 100 and 112 mm,
 - power 0.45 to 3 kW.

Use conditions

S1 duty, when environment requires an enclosed motor.
 Altitude lower than 1000 m.
 Ambient temperature less than or equal to 40 °C.
 Current range from 50 to 100% of IN in continuous operation and higher in transient operation.
 N.B.: refer to the technical catalogue to check axial or radial loads, overload capacities, motor protection system.



Component	Materials	Remarks
Stator (or casing)	Steel casing	
Inductors - MFA - MF	Permanent magnets Layered magnetic pole Enameled electrolytic copper	- high coercive field - welded pre-stressed sheet steel assembly using TIG process - insulation system class F
Armature	Insulated low carbon magnetic steel laminations Enameled electrolytic copper	- formed on automatic machines for repeat accuracy and reliability - binding reinforced with heat-treated polymerised fibreglass on the commutator end - insulation system class F
Commutator	Silver-plated copper on resin	- large number of blades
Shaft	Steel	- open keyway - straight-ended key
Brushes	Electrographitic compound	- easy access via plug on the motor side
End shields	Aluminium alloy Cast iron	- front end shield, plain holes flange FF, or tapped holes FT - rear shield with cooling fins
Bearings and lubrication	Steel	- ball bearings, set C3 - type 2RS, sealed, greased for life - preloaded on the bearing : <ul style="list-style-type: none"> • rear for MFA 80 • front for MF 100 and 112
Fan	Composite material Aluminium alloy or sheet steel	- self-cooled motor (speed range from 1 to 10) - forced axial ventilation (speed range from 1 to 100)
Terminal box	Composite material (MFA 56, 63) Metal (other types)	- placed on top of the motor - output via cable glands, on the right when seen from the shaft end (MFA 56, 63) - output via cable glands, on the left when seen from the shaft end (MFA 80, MF 100, 112) - connection to a terminal board

Armature voltage according to power supplies		
Single phase sector	Maximum armature voltage	
	Variable speed drive	
	1 quadrant	4 quadrants
V	V	V
220 - 230 - 240	180	180
380 - 400	310 - 320	250 - 260
415	340	270

Excitation voltage according to power supplies	
Single phase sector	Excitation voltage
V	V
220 - 230	190 - 210
240	220
220 - 230 - 240	Magnets

Enclosed continuous current (DC) motors MFA - MF

Mounting positions

Foot mounted motors

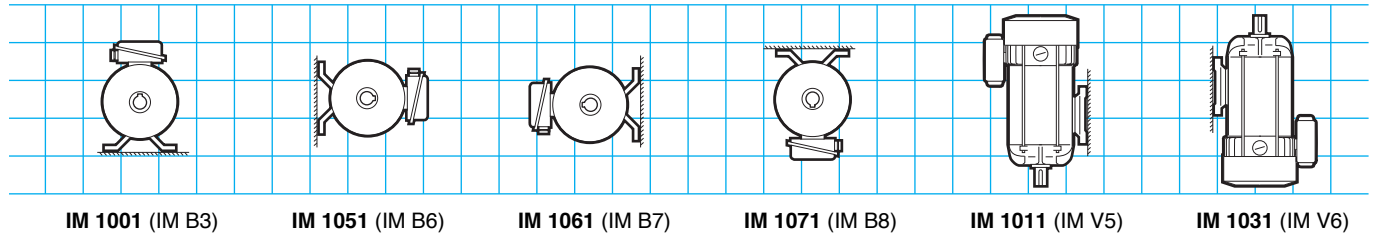

(FF) plain hole flange mounted motor

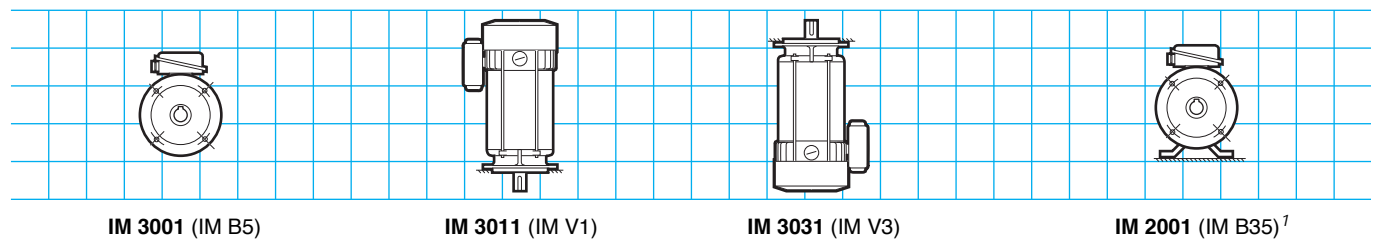

1. Foot and flange position.

(FT) tapped hole flange mounted motor

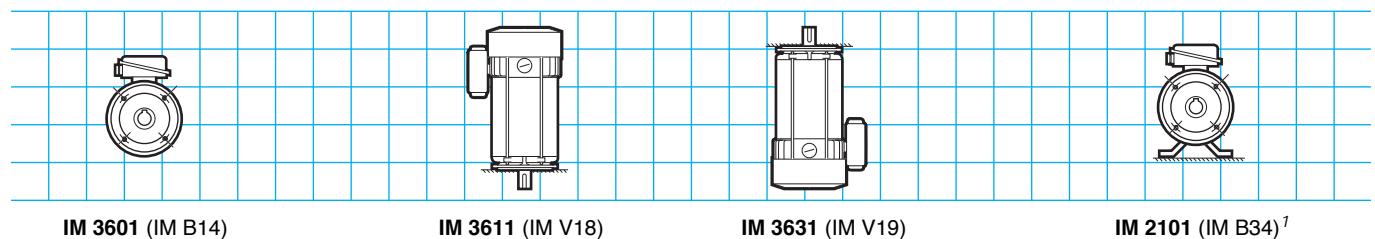

1. Foot and flange position.

Terminal box position (TB)

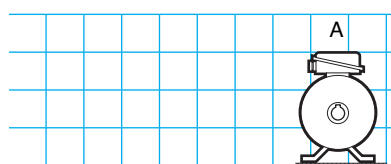

A : standard

Cable gland position

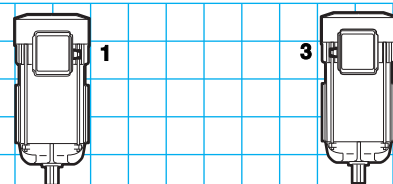

The only possibility
MFA 80 - MF 100, 112

Enclosed continuous current (DC) motors MFA - MF

Adaptation possibilities

MFA - MF motors may be associated to :

• gearboxes with universal or integrated mounting :

- with parallel or coaxial axes : Cb 1000, Cb 3000,
- conical torque Ot 2000,
- hollow shaft Mub 2000,
- worm and wheel : Minibloc, Mb 2000,
- planetary gear PI 2000.

• electronic variable speed drive :

- 1 quadrant : VE/A, VE/B, DMV 201,
- 4 quadrants VE/RG, DMV 242.

The options :

• tapped hole or plain hole flange

- detection of hollow shaft speed (i) :**
- tachometer dynamo, 20 V / 1000 min⁻¹,
 - tacho alternator, 30 V / 1000 min⁻¹ ;

• safety brakes (t), with or without release lever :

- for MFA 56 to 63 : 2.5 N.m, 190 V c.c
- for MFA 80 : 8 N.m, 190 V c.c
- MF 100-112 : 16 N.m, 190 V c.c

• forced ventilation (')

• possible combinations:

- i + ' +
- t + i +
- t + ' +
- t + i + ' +

Leroy-Somer offers various options and adaptation possibilities for its motors. They are described below and offered in this catalogue, in the section relating to gearboxes, or in the section on speed variation for the types of motorised variable speed drives selected.

For the applications not specified in the selection tables, consult the technical specialists at Leroy-Somer.

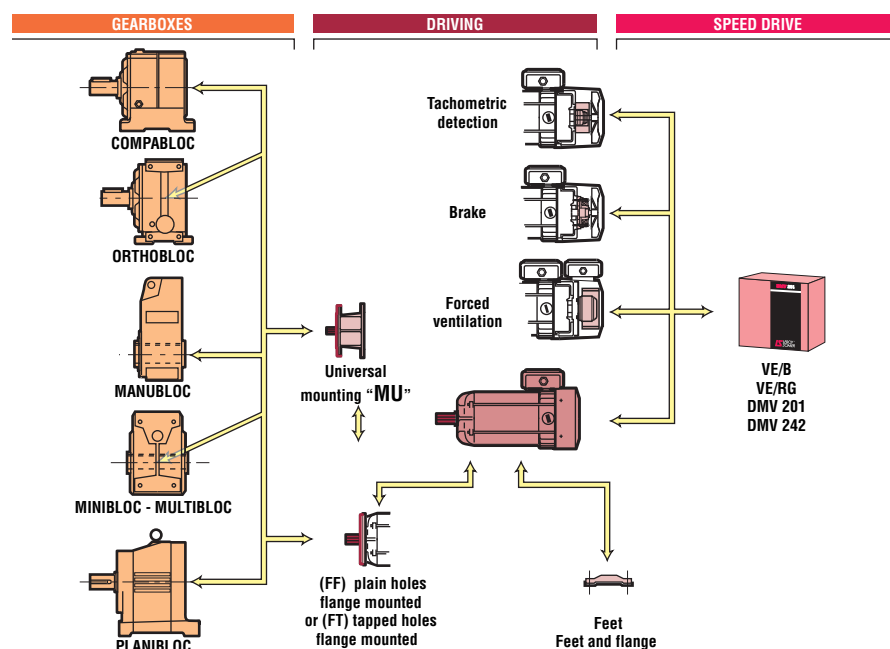

Designation / Codification

MF	112	L 02	260 V	2000 min⁻¹	1.85 kW	IM 1001	190 V	IC 411	IP 44
Motor type	Frame size Polarity	Stator designation Builder index	Armature voltage	Rated speed	Rated power	Construction form	Excitation voltage	Cooling index	Protection index

Codification example :

Motor 1.85 kW, 2000 min⁻¹, IM 1001, 260/190 V

Designation
MF 112 L02 1.85 kW

Code
-

All the products in this catalogue have a code.

The coding table is incorporated in the price list together with the list of designations.

Each electromechanical product is classified first in order of power and then in order of speed.

Enclosed continuous current (DC) motors MFA - MF

Preselection chart

+ Selection example :

Data:

- 0.7 kW at 1950 min⁻¹,
- variable speed drive output voltage 180V,
- supply by thyristor.

Operating mode:

- Preselect the motor size using the chart opposite : MFA 80.

- In the selection table look for the form factor 1.6 (due to the variable speed drive type) the power closest to 0.7 kW (see the following page, the extract of which appears below) : P = 0.75 kW at 2000 min⁻¹.

How can the rated speed be adjusted to the required speed ?

By adjusting the armature voltage (output of the variable speed drive), without exceeding the rated value, the power being corrected proportionally.

In this situation, in order to be used at 1850 min⁻¹, the motor will be supplied at

$$180 \times \frac{1950}{2000} = 175.5 \text{ V,}$$

$$\text{and } P = 0.75 \times \frac{175.5}{180}, \text{ or } 0.73 \text{ kW.}$$

Selected motor :

MFA 80 L - 180 V - 0.75 kW...
IC 01

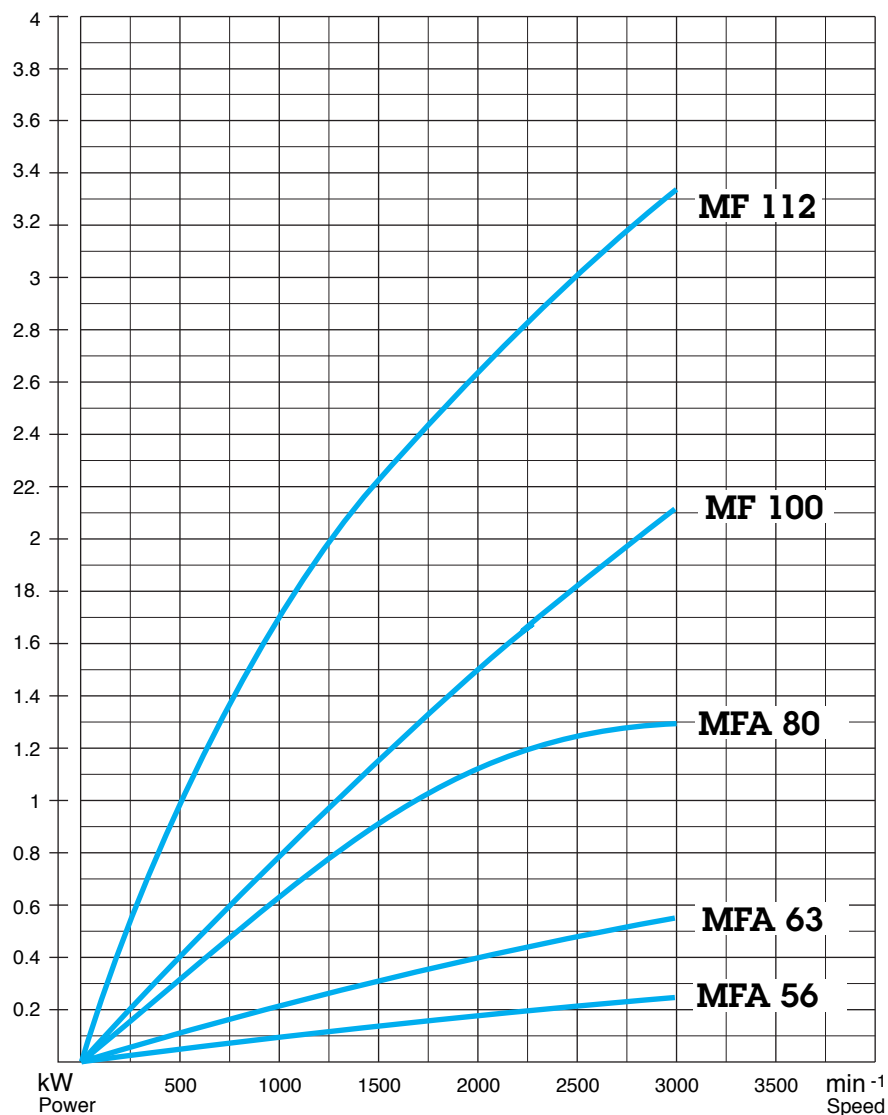

P	n	M _N	I	η	MFA	Manuf.
For armature voltage 180 V					Size	index
kW	min ⁻¹	N.m	A	except for excit.		
0.075	3000	0.24	0.6	0.62	56	S
0.12	3000	0.38	1	0.58	56	S
0.18	3000	0.57	1.2	0.69	63	S
0.25	3000	0.80	1.9	0.71	63	M
0.37	3000	1.18	2.4	0.791	63	L
0.37	2000	1.77	2.7	0.761	80	S
0.37	3000	1.18	3.7	0.556	80	S
0.55	2000	2.63	3.7	0.826	80	L
0.55	3000	1.75	5.1	0.599	80	L
0.75	2000	3.58	5.1	0.817	80	L
0.75	3000	2.39	4.9	0.85	80	L
1	2000	4.78	6.6	0.842	80	VL

Enclosed continuous current (DC) motors MFA - MF

Selection

MFA IP 44 motor - Class F
Excitation by permanent magnets
Supply by thyristor (1.6 form factor)
S1 duty - Ambient temperature $\leq 40\text{ }^{\circ}\text{C}$ - Altitude $< 1\ 000\ \text{m}$



P kW	n min ⁻¹	M_N N.m	I A	η except for excit.	L mH	$R_{115^{\circ}}$ Ω	U_{\max} V	Inertia moment $10^{-3}\ \text{kg.m}^2$	MFA size	Manuf. index
0.075	3000	0.24	0.6	0.62	88	29.37	200	0.26	56	S
0.12	3000	0.38	1	0.58	23	11.84	200	0.51	56	L
0.18	3000	0.57	1.2	0.69	32	6.71	200	1.3	63	S
0.25	3000	0.80	1.9	0.71	21	4.25	200	1.7	63	M
0.37	3000	1.18	2.4	0.75	14.3	2.53	200	2.5	63	L
0.37	2000	1.77	2.7	0.761	46	8	200	2.5	80	S
0.37	3000	1.18	3.7	0.556	24	3.3	200	2.5	80	S
0.55	2000	2.63	3.7	0.826	36	2.65	200	5	80	L
0.55	3000	1.75	5.1	0.599	17	1.8	200	5	80	L
0.75	2000	3.58	5.1	0.817	25	2.65	200	5	80	L
0.75	3000	2.39	4.9	0.85	18	1.8	200	5	80	L
1	2000	4.78	6.6	0.842	20	1.99	200	7.5	80	VL
1	3000	3.18	7.6	0.731	12	0.9	200	7.5	80	VL

Selection example : see page B2.4.



Maximal current not to be exceeded :
1.6 times the rated current ; if not it risks
demagnetisation of the magnets.

P : Rated power
 n : Rated speed $\pm 10\%$
 M_N : Rated moment
 I : Rated current
 η : Efficiency
 U_{\max} : Maximum armature voltage
 L : Motor self-induction coil
 $R_{115^{\circ}}$: Armature resistance at 115°C

1. FF : current form factor.

Enclosed continuous current (DC) motors MFA

Selection

MFA IP 44 motor - Class F
Excitation by permanent magnets
Supply by transistor (1.05 form factor)
S1 duty - Ambient temperature $\leq 40\text{ }^{\circ}\text{C}$ - Altitude $< 1000\text{m}$

FF¹
1.05

P kW	n min ⁻¹	M_N N.m	I A	h except for excit.	L mH	$R_{115^{\circ}}$ Ω	U_{\max} V	Inertia moment 10^{-3} kg.m^2	MFA size	Manuf. index
0.09	3000	0.29	0.65	0.7	88	29.37	200	0.26	56	S
0.18	3000	0.57	1	0.83	23	11.84	200	0.51	56	L
0.3	3000	0.96	2.1	0.83	32	6.71	200	1.3	63	S
0.45	3000	1.43	2.6	0.83	21	2.53	200	1.7	63	M
0.55	3000	1.75	3.5	0.86	14.3	2.53	200	2.5	63	L
0.45	2000	2.15	3.1	0.806	39	8	200	2.5	80	S
0.55	3000	1.75	3.7	0.826	24	3.3	200	2.5	80	S
0.66	2000	3.15	4.5	0.815	29	2.65	200	5	80	L
0.75	3000	2.39	5.3	0.786	17	1.8	200	5	80	L
0.9	2000	4.3	6.1	0.82	21	2.65	200	5	80	L
1	3000	3.18	6.8	0.817	13	1.8	200	5	80	L
1.2	2000	5.73	7.9	0.844	16	1.99	200	7.5	80	VL
1.3	3000	4.14	8.6	0.84	10	0.9	200	7.5	80	VL

Selection example : see page B2.4.



Maximal current not to be exceeded :
1.6 times the rated current ; if not it risks
the demagnetisation of the magnets.

P : Rated power
 n : Rated speed $\pm 10\%$
 M_N : Rated moment
 I : Rated current
 η : Efficiency
 U_{\max} : Maximum armature voltage
 L : Motor self-induction coil
 $R_{115^{\circ}}$: Armature resistance at 115°C

1. FF : current form factor.

Enclosed continuous current (DC) motors MF 100 L

Selection

IP 44 motor - Class F
Separate excitation : 190 V ± 10 %
Supply by rectified single phase current, with or without self-induction coil
S1 duty - Ambient temperature ≤ 40 °C - Altitude < 1 000 m

P with self-induction coil kW	P without self-induction coil kW	Rotating speed n for voltage U						M _N ¹ N.m	I ¹ A	η without excit.	L mH	R _{115°} Ω	U _{max} V	Manuf. index
		150 V min ⁻¹	180 V min ⁻¹	230 V min ⁻¹	250 V min ⁻¹	260 V min ⁻¹	310 V min ⁻¹							
0.51	0.45	660					6.51	4	0.755	182	5.22	340	01	
0.63	0.56		820				6.52	4	0.78	182	5.22	340	01	
0.82	0.73			1080			6.46	4	0.796	182	5.22	340	01	
0.9	0.8				1190		6.42	4	0.8	182	5.22	340	01	
0.95	0.84					1240	6.47	4	0.813	182	5.22	340	01	
1.13	1					1500	6.37	4	0.81	182	5.22	340	01	
0.8	0.7	1000					6.69	5.5	0.858	93	2.5	340	02	
0.96	0.85		1230				6.6	5.5	0.86	93	2.5	340	02	
1.24	1.1			1600			6.57	5.5	0.87	93	2.5	340	02	
1.36	1.2				1750		6.55	5.5	0.877	93	2.55	340	02	
1.42	1.25					1830	6.52	5.5	0.88	93	2.55	340	02	
1.7	1.5					2200	6.51	5.5	0.883	93	2.55	340	02	
0.93	0.83	1230					6.44	6.7	0.824	64	1.66	340	03	
1.13	1		1500				6.37	6.7	0.83	64	1.66	340	03	
1.47	1.3			1950			6.37	6.7	0.845	64	1.66	340	03	
1.61	1.43				2130		6.41	6.7	0.854	64	1.66	340	03	
1.68	1.49					2260	6.3	6.7	0.856	64	1.66	340	03	
2	1.78					2670	6.37	6.7	0.859	64	1.66	340	03	
1.39	1.22	1800					6.47	9.6	0.85	30	1.08	250	04	
1.7	1.5		2200				6.51	9.6	0.868	30	1.08	250	04	
2.18	1.92			2870			6.39	9.6	0.87	30	1.08	250	04	

1. Values given for supply without self-induction coil: form factor FF = 1.6 ; for FF = 1.2 (use of an additional self-induction coil), multiply these values by 1.13.

Selection example : see page B2.4.

Inertia moment
Excitation power at 20°C

13 10⁻³ kg.m²
60W

P : Rated power
n : Rated speed ± 10%
M_N : Rated moment
I : Rated current
η : Efficiency
L : Motor self-induction coil
R_{115°} : Armature resistance at 115°C
U_{max} : Maximum armature voltage

Enclosed continuous current (DC) motors MF 112 L

Selection

IP 44 motor - Class F
Separate excitation : 190 V ± 10 %
Supply by rectified single phase current , with or without self-induction coil
S1 duty - Ambient temperature ≤ 40 °C - Altitude < 1000 m

P with self-induction coil kW	P without self-induction coil kW	Rotating speed <i>n</i> for voltage <i>U</i>						M_N^1 N.m	I^1 A	η without excit.	L mH	R_{115° Ω	U_{max} V	Manuf. index
		150 V min ⁻¹	180 V min ⁻¹	230 V min ⁻¹	250 V min ⁻¹	260 V min ⁻¹	310 V min ⁻¹							
0.72	0.64	660					9.26	5.4	0.793	137	3.3	340	01	
0.88	0.78		830				8.97	5.4	0.808	137	3.3	340	01	
1.15	1			1090			8.76	5.4	0.821	137	3.3	340	01	
1.25	1.1				1190		8.83	5.4	0.823	137	3.3	340	01	
1.31	1.16					1240	8.93	5.4	0.83	137	3.3	340	01	
1.58	1.4					1500	8.91	5.4	0.839	137	3.3	340	01	
1.16	1.03	1100					8.94	8.5	0.808	55	1.43	340	02	
1.41	1.25		1350				8.84	8.5	0.816	55	1.43	340	02	
1.84	1.63			1750			8.9	8.5	0.835	55	1.43	340	02	
2.01	1.78				1910		8.9	8.5	0.839	55	1.43	340	02	
2.1	1.85					2000	8.83	8.5	0.84	55	1.43	340	02	
2.51	2.21					2400	8.79	8.5	0.842	55	1.43	340	02	
1.3	1.15	1230					8.93	9.4	0.816	44.5	0.83	340	03	
1.58	1.4		1500				8.91	9.4	0.831	44.5	0.83	340	03	
2.05	1.81			1930			8.96	9.4	0.838	44.5	0.83	340	03	
2.23	1.97				2110		8.92	9.4	0.839	44.5	0.83	340	03	
2.32	2.05					2200	8.9	9.4	0.84	44.5	0.83	340	03	
2.78	2.45					2640	8.86	9.4	0.844	44.5	0.83	340	03	
2.06	1.81	1990					8.69	14	0.867	19.5	0.36	200	04	
2.49	2.2		2400				8.75	14	0.875	19.5	0.36	200	04	

1. Values given for supply without self-induction coil: form factor $FF = 1.6$; for $FF = 1.2$ (use of an additional self-induction coil), multiply these values by 1.13.

Selection example : see page B2.4.

Inertia moment
Excitation power at 20°C

$30 \cdot 10^{-3} \text{ kg.m}^2$
60W

P : Rated power
 n : Rated speed ± 10%
 M_N : Rated moment
 I : Rated current
 η : Efficiency
L : Motor self-induction coil
 R_{115° : Armature resistance at 115°C
 U_{max} : Maximum armature voltage

Enclosed continuous current (DC) motors MF 112 VL

Selection

IP 44 motor - Class F
Separate excitation : 190 V ± 10 %
Supply by rectified single phase current, with or without self-induction coil
S1 duty - Ambient temperature ≤ 40 °C - Altitude < 1 000 m

<i>P</i> with self-induction coil kW	<i>P</i> without self-induction coil kW	Rotating speed <i>n</i> for voltage <i>U</i>						M_N^1 N.m	<i>I</i> ¹ A	η without excit.	<i>L</i> mH	R_{115° Ω	U_{max} V	Manuf. index
		150 V min ⁻¹	180 V min ⁻¹	230 V min ⁻¹	250 V min ⁻¹	260 V min ⁻¹	310 V min ⁻¹							
1.1	0.93	670					13.26	8	0.775	51	1.72	330	02	
1.35	1.16		810				13.68	8	0.8	51	1.72	330	02	
1.75	1.52			1060			13.69	8	0.826	51	1.72	330	02	
1.9	1.67				1160		13.75	8	0.835	51	1.72	330	02	
2	1.75					1210	13.81	8	0.841	51	1.72	330	02	
2.4	2.1						13.83	8	0.848	51	1.72	330	02	
1.25	1.1	950					11.06	9	0.81	27	1.03	330	03	
1.5	1.33		1140				11.14	9	0.82	27	1.03	330	03	
2	1.74			1460			11.38	9	0.841	27	1.03	330	03	
2.15	1.9				1600		11.34	9	0.845	27	1.03	330	03	
2.3	2					1670	11.44	9	0.852	27	1.03	330	03	
2.7	2.38						11.36	9	0.855	27	1.03	330	03	
1.6	1.4	1400					9.55	11.2	0.832	15	0.43	330	04	
2	1.7		1700				9.55	11.2	0.848	15	0.43	330	04	
2.5	2.21			2200			9.59	11.2	0.858	15	0.43	330	04	
2.7	2.4				2400		9.55	11.2	0.861	15	0.43	330	04	
2.9	2.5					2500	9.55	11.2	0.861	15	0.43	330	04	
3.5	3						3000	9.55	11.2	0.861	15	0.43	330	04

1. Values given for mains supply without self-induction coil: form factor $FF = 1.6$; for $FF = 1.2$ (use of an additional self-induction coil), multiply these values by 1.13.

Selection example : see page B2.4.

Inertia moment
Excitation power at 20°C

$36.5 \cdot 10^{-3} \text{ kg.m}^2$
60W

P : Rated power
n : Rated speed ± 10%
 M_N : Rated moment
I : Rated current
 η : Efficiency
L : Motor self-induction coil
 R_{115° : Armature resistance at 115°C
 U_{max} : Maximum armature voltage

Enclosed continuous current (DC) motors MFA - MF

Availability according to the construction

Type ¹	Construction characteristics	
MFA 56 (3000 min ⁻¹)	<ul style="list-style-type: none"> • IP 44 protection • Self-ventilated • Axial forced ventilation from MFA 80 upwards • Foot mounted • Flange, or foot and flange mounting from MFA 80 upwards : <ul style="list-style-type: none"> - plain holes (FF) • Terminal box in position A, cable glands (PE) see page B2.2 • Standard main shaft end • Sealed ball bearings • Balancing class N normal • Mounting of a tachometric dynamo (DT) from MFA 80 upwards : <ul style="list-style-type: none"> - TD3 alternator or similar (30 V three-phase rectified) - KTD3 dynamo or similar (continuous 20 V) • Separate excitation : <ul style="list-style-type: none"> - 190 V voltage for MF 100 L 04 - MF 112 L 04 - 170 V voltage for MF 100 L 02 - MF 112 L 02 - 170 V voltage for MF 112 VL 04 	
MFA 63 (3000 min ⁻¹)		
MFA 80 (2000 min ⁻¹)		
MF 100 L 02		
MF 100 L 04		
MF 112 L 02		
MF 112 L 04		
MF 112 VL 04		
MFA 56 (3000 min ⁻¹)		<ul style="list-style-type: none"> • Flange and foot or flange mounting : <ul style="list-style-type: none"> - plain holes (FF) all sizes - tapped holes (FT) up to MFA 63 • Mounting of a tachometric dynamo (DT) : <ul style="list-style-type: none"> - TD3 alternator or similar (30 V three-phase rectified) - KTD3 dynamo or similar (continuous 20V) • Brake mounting : (rectified direct current 190V) <ul style="list-style-type: none"> - 2.5 N.m up to MFA 63 (with or without lever) - 8 N.m for MFA 80 • Tachometric dynamo and brake (except for MFA 56 and 63) • Tachometric dynamo or brake (for MFA 56 and 63)
MFA 63 (3000 min ⁻¹)		
MFA 80 (2000 min ⁻¹)		
MF 100 L 02		
MF 100 L 04		
MF 112 L 02		
MF 112 L 04		
MF 112 VL 04		
MFA 80	<ul style="list-style-type: none"> • Tapped hole flange • Other flanges available on request • Special shaft end on request • 2nd shaft option • Balancing class R reduced • Lipseals in the flange • Brake with release lever • CTP thermal detection (only MF) • IP 55 option • Brake mounting : (rectified direct current 190 V) <ul style="list-style-type: none"> - 16 N.m for MF 100 and MF 112 • Other excitation voltages (220 V max) 	
MF 100		
MF 112		

1. All MFA 56 and MFA 63 in normal manufacturing time regardless of construction.

Enclosed continuous current (DC) motors MFA - MF

Notes

B

Enclosed continuous current (DC) motors MFA - MF

Dimensions

Dimensions of the MFA - MF enclosed continuous current (dc) motors

Dimensions in millimetres

- foot mounted

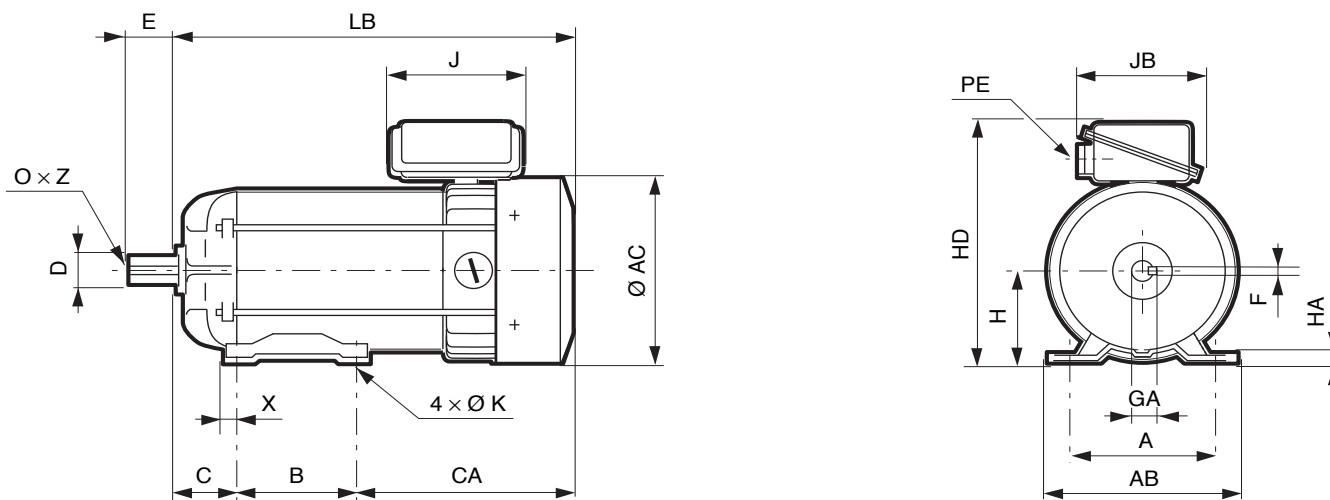

- (FF) plain hole flange mounted

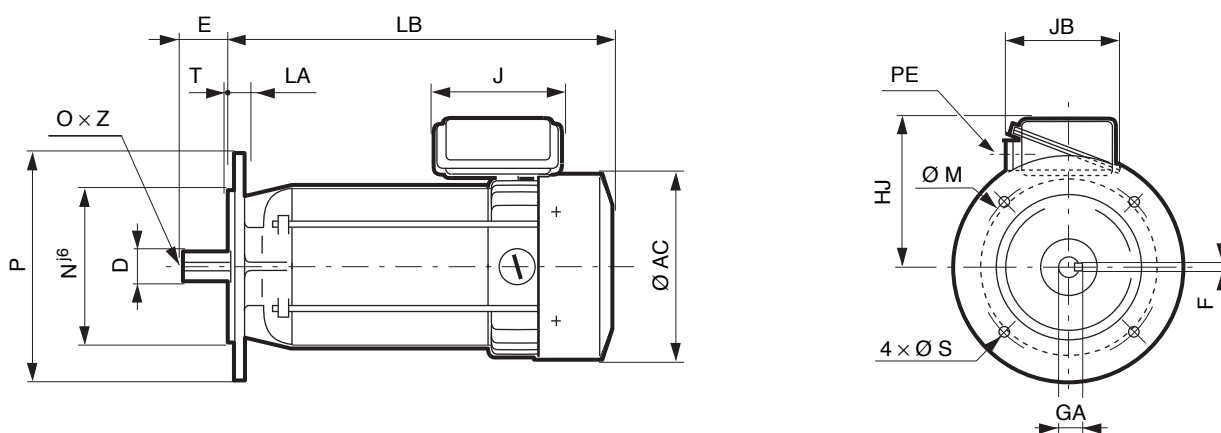

- (FT) tapped hole flange mounted

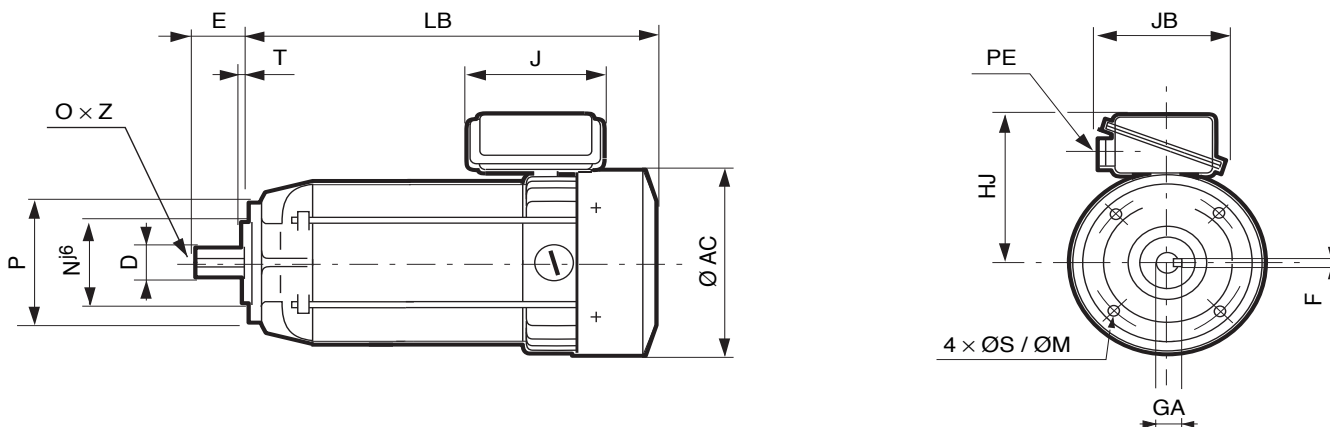

Enclosed continuous current (DC) motors MFA - MF

Dimensions

Dimensions of the MFA - MF enclosed continuous current (dc) motors

Dimensions in millimetres

Type	Motors														Weight	
	A	AB	AC	B	C	CA	H	HA	HD	J	JB	K	LB ¹	X	PE ²	kg
MFA 56 S	90	108	108	71	36	52	56	2	127	49	49	6	159	9	9	2.9
MFA 56 L	90	108	108	71	36	92	56	2	127	49	49	6	199	9	9	3.5
MFA 63 S	100	120	134	80	40	77	63	2	161	78	75	7	197	10	11	7.5
MFA 63 M	100	120	134	80	40	102	63	2	161	78	75	7	222	10	11	9.2
MFA 63 L	100	120	134	80	40	132	63	2	161	78	75	7	252	10	11	11
MFA 80 S	125	155	158	100	50	108	80	3	213	95	100	9	258	10	16	14
MFA 80 L	125	155	158	100	50	158	80	3	213	95	100	9	308	10	16	18
MFA 80 VL	125	155	158	100	50	208	80	3	213	95	100	9	358	10	16	22
MF 100 L	160	196	195	254	63	163	100	5	243	95	100	12	480	12	16	42
MF 112 L	190	230	220	254	70	222	112	5	270	95	100	12	510	22	16	59
MF 112 VL	190	230	220	254	70	222	112	5	270	95	100	12	595	22	16	62

1. In plain hole flange version (B5) LB = + 4 mm for MFA 56 and + 11 mm for MFA 63.

2. Cable glands (PE) on the right for MFA 56 to 80 motor types .

Type	(FF) plain hole flange							(FT) tapped hole flange					Shaft end					
	HJ	M	N	P	LA	S	T	M	N	P	S	T	D j6	E	F	GA	O	Z
MFA 56 S/L	71	100	80	120	8	7	3	65	50	80	M5	2.5	11	23	4	12.5	M4	10
MFA 63 S/M/L	98	115	95	140	10	9	3	75	60	120	M5	2.5	11	23	4	12.5	M4	10
MFA 80 L/VL	133	165	130	200	10	11	3.5	100	80	130	M6	3	19	40	6	21.5	M6	16
MFA 100 L	143	165	130	200	12	11	3.5	130	110	160	M8	3.5	24	50	8	27	M10	22
MFA 112 L/VL	158	215	180	250	12	14	4	130	110	160	M8	3.5	28	60	8	31	M10	22

Enclosed continuous current (DC) motors MFA - MF

Dimensions

Dimensions of the MFA - MF enclosed continuous current (dc) motors

Dimensions in millimetres

- foot, flange or foot and flange mounted

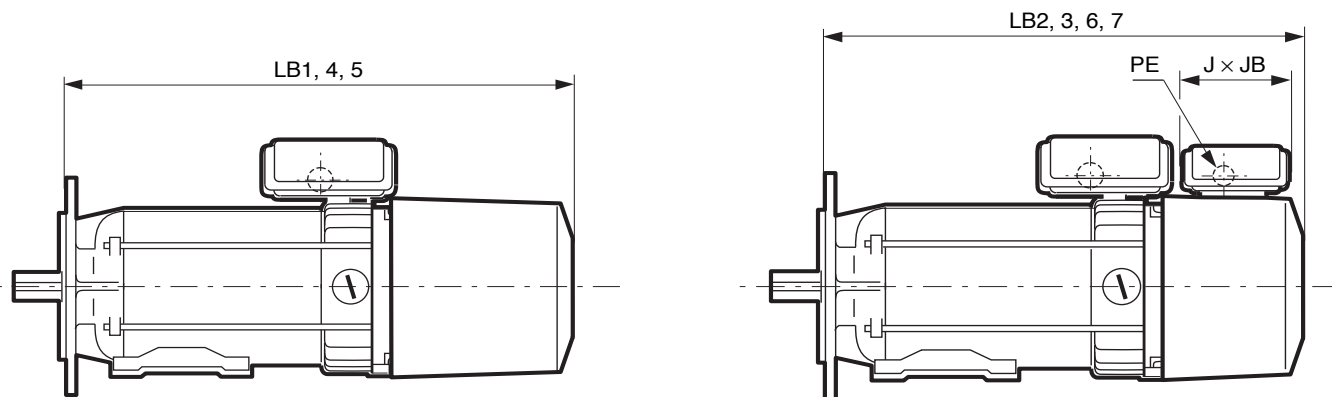

Type	Motors with options								Auxiliary terminal box		
	i (=)	i (~)	'	i'	t	t i	t'	t i'	J	JB	PE
MFA 56 S	210	193	-	-	203	-	-	-	-	-	-
MFA 56 L	250	233	-	-	243	-	-	-	-	-	-
MFA 63 S	245	228	-	-	238	-	-	-	-	-	-
MFA 63 M	270	253	-	-	263	-	-	-	-	-	-
MFA 63 L	300	283	-	-	293	-	-	-	-	-	-
MFA 80 S	305	292	399	399	305 ²	352	399	429	98	94	16
MFA 80 L	355	342	449	449	355 ²	402	449	479	98	94	16
MF 80 VL	405	392	499	499	399 ²	452	499	529	98	94	16

1. For the brake release lever, total length LB4 + 10 mm.
2. For CMR motors, this size is the same as LB6.

Symbols used for the options

i : hollow shaft speed detection
t : safety brakes
' : forced ventilation
= : rectified current
~ : alternative current

Type	Motors with options						
	i	'	i'	t	t i	t'	t i'
MF 100	527	537	580	527	580	580	630
MF 112	556	556	606	556	606	606	651
Auxiliary terminal box	-	•	•	-	-	•	•

Type	• Auxiliary terminal box		
	J	JB	PE
MF 100	98	94	16
MF 112	110	130	21